

Princess

Oggetto dal forte messaggio evocativo ispirato dalla letteratura (*Antoine De Saint-Exupery*) "Le petit prince". Il dono d'amore per eccellenza, la rosa, simbolo ed archetipo del bel gesto, è qui trattata in fine porcellana lucida con decorazioni preziose e raffinate. Delimitata a sua volta da un solido neoplatonico in metallo e legno, che la racchiude e protegge nel suo spazio di rispetto e di quiete.

Object with a strong evocative message inspired by literature (Antoine De Saint-Exupery) "Le petit prince". The gift of love par excellence, the rose, symbol and archetype of the nice gesture, it's here treated in fine shiny porcelain with precious and refined decorations. Delimited in turn by a neoplatonic solid made in metal and wood, which encloses and protects it in its space of respect and quiet.



Princess







Immagine prospettica dell'urna Princess nella decorazione polvere di stelle oro zecchino
Perspective image of the Princess urn in pure gold stardust decoration.



Particolare della rosa dall'alto con decorazione polvere di stelle oro zecchino
Top view section of rose in pure gold stardust decoration



Princess - Art. PRI 01

- Polvere di Stelle in Oro Zecchino sui petali
- Pure Gold Stardust on petals



Princess - Art. PRI 02

- Bianco Lucido
- Glossy White



Princess - Art. PRI 03

- Polvere di Stelle in Oro Zecchino e Petali in Oro dipinti a mano
- Pure Gold Stardust and hand-painted Pure Gold petals



Picture

L'Urna Picture è un solido decostruito, un "CASE" immortalato proprio nel momento della sua apertura, una sorta di carillon in metallo e pietra ceramica. Le superfici, rese interessanti da preziosismi e quadri d'autore, richiamano ai canoni della bellezza "fauves" ; avvolgendo l'urna attraverso il concetto dell'eterna bellezza della pittura. Oggetto poliedrico che spazia con i suoi registri estetici dall'hi-tech al classico decorativismo. Versatilità accentuata anche dalla duplice possibilità applicativa, ideato infatti per poter essere collocato sia come oggetto da appoggio che come moderno quadro da appendere alla parete. Realizzato in metallo verniciato a polvere rivestito da pannelli in pietra ceramica decorati.

The Picture Urn is a deconstructed solid, an immortalized "CASE" just in the moment of its opening, a sort of carillon in metal and ceramic stone. The surfaces are made interesting by preciousness and authors paintings, recall the "Fauves" canons of beauty; wrapping the urn through the concept of the eternal beauty of painting. A multifaceted object which ranges with its aesthetic registers from hi-tech to classic decoration. Versatility is also accentuated by the dual application possibilities, designed in fact to be able to be placed both as a free-standing object and as a modern picture to be hanged to the wall. Made of powder-coated metal covered with decorated ceramic stone panels.

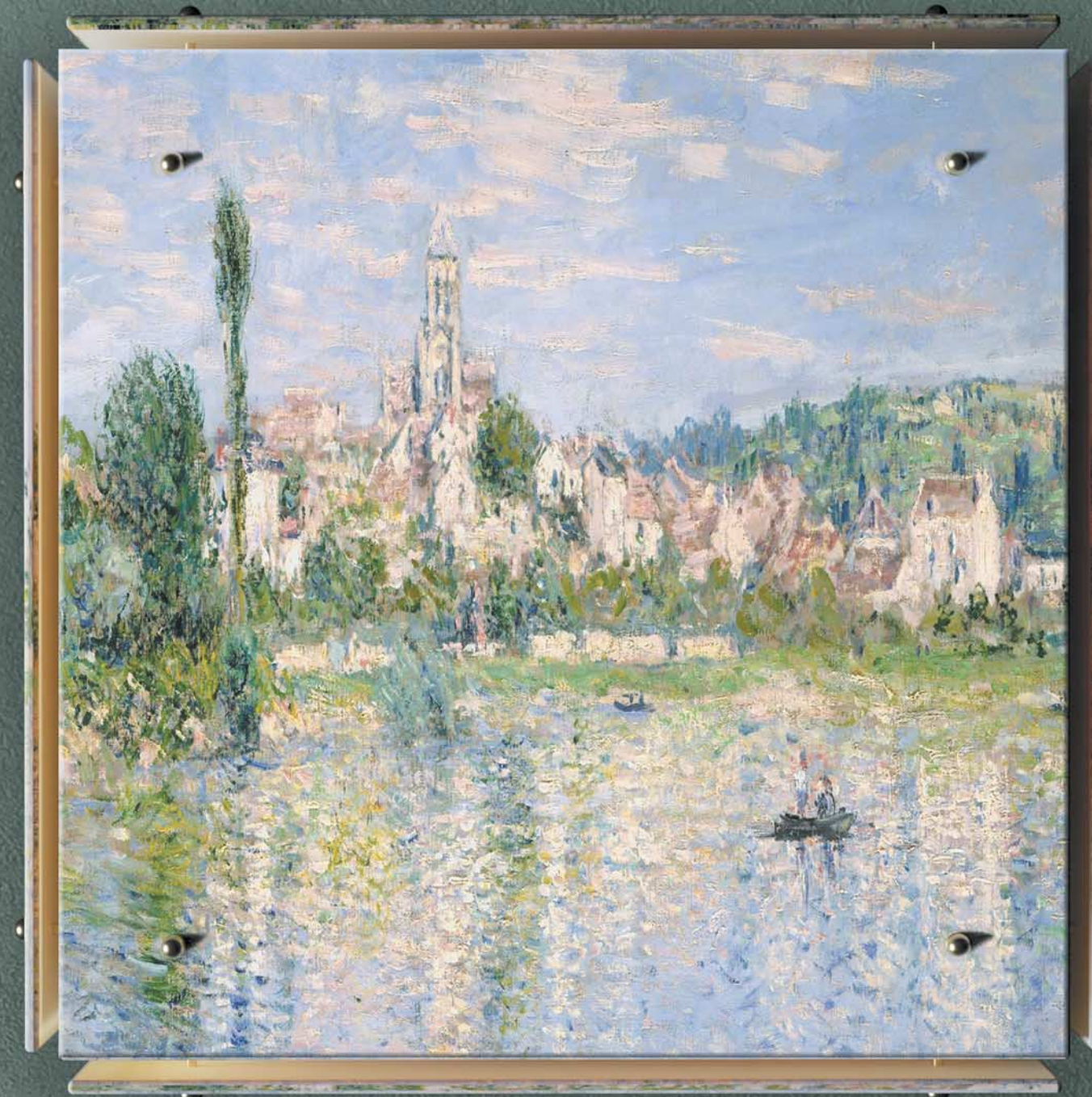



CONCEPT

In questa soluzione a parete troviamo tutte le caratteristiche classiche di un dipinto del '900 che si rinnovano in spazi moderni e minimali; tutto ciò invita alla contaminazione di più stili per conservare il ricordo della contemporaneità.

In this wall solution we find all the classic characteristics of a 20th century paintings which are renewed in modern and minimal spaces; everything invites to the contamination of multiple styles in order to preserve the memory of contemporaneity.



Picture - Art. PIC 01

- Vincent Van Gogh "Notte stellata"
- Vincent Van Gogh "Starry night"



Picture - Art. PIC 02

- Claude Monet "I papaveri"
- Claude Monet "The poppies"



Picture - Art. PIC 03

- Claude Monet "Paesaggio al parco Monceau"
- Claude Monet "Landscape at Monceau park"



Picture - Art. PIC 04

- Vincent Van Gogh "Iris"
- Vincent Van Gogh "Iris"



Picture - Art. PIC 05

- Claude Monet "Vetheuil in estate"
- Claude Monet "Vetheuil in summer"

Cassa interna in Metallo verniciato Oro Satinato
internal box in satin gold painted metal



Picture - Art. PIC 06

- Vincent Van Gogh "Campo di grano con cipressi"
- Vincent Van Gogh "Wheat field with cypresses"

CONCEPT

Utilizzato in appoggio, diviene un vero e proprio oggetto di arredamento che aggiunge una vena di eleganza e raffinatezza ad un ambiente sobrio e contemporaneo.

Placed on a surface, it becomes a real furnishing object which adds a vein of elegance and refinement to a sober and contemporary environment.





Picture - Art. PIC 07

- Marmo Carrara con Venature in Oro Zecchino
- Carrara Marble with Pure Gold veins

Cassa interna in Metallo verniciato Oro Satinato
internal box in satin gold painted metal

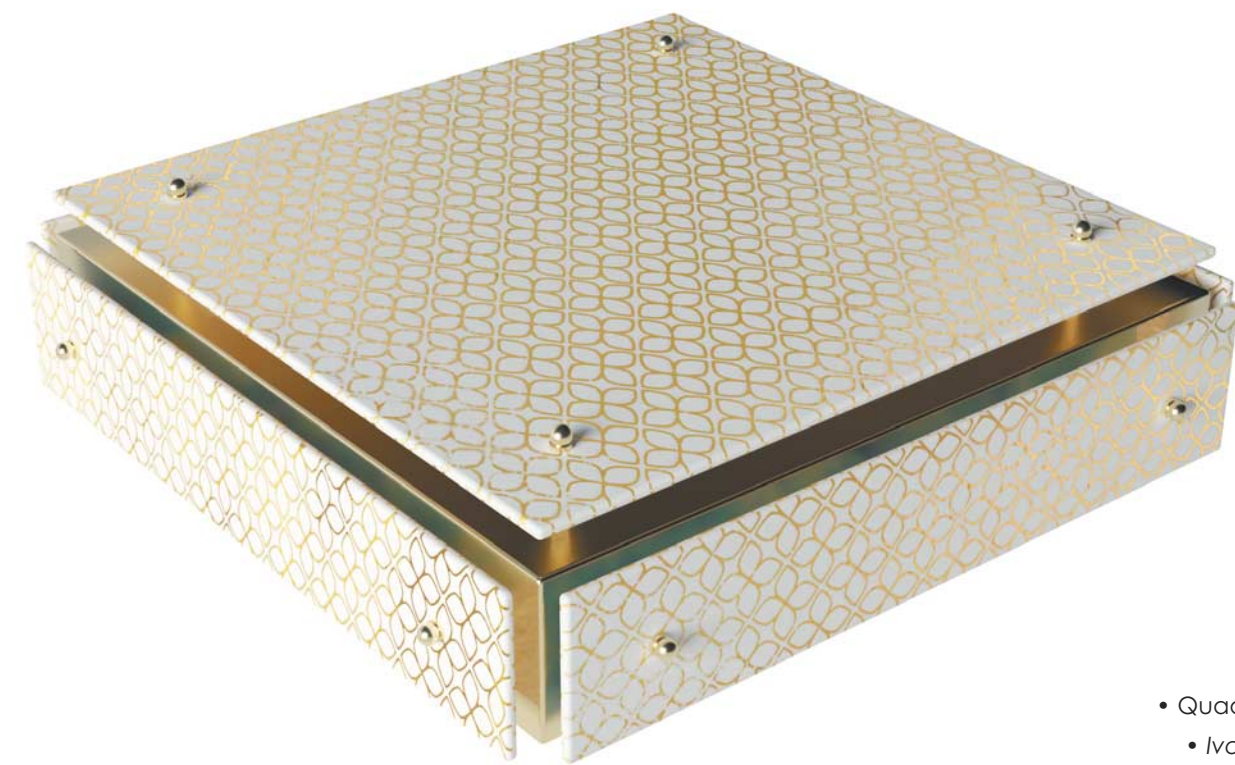

Picture - Art. PIC 09

- Quadrifoglio Avorio/Oro Zecchino a Rilievo
- Ivory/Pure Gold Four-leaf Clover in Relief

Cassa interna in Metallo verniciato Oro
internal box in gold painted metal



Picture - Art. PIC 08

- Foglie Oro Zecchino
- Pure Gold Leaves



Picture - Art. PIC 10

- Texture Natura a Rilievo con Oro in Pasta
- Nature Texture in Relief with Paste Gold



Lovely

Un cuore velato, Simbolo POP dal significato universale, in questa soluzione risolto attraverso il messaggio del velo che si prende cura dell'amore donato. La porcellana, è modellata come un tessuto, formando un delicato panneggio dal quale emerge il plasticismo del cuore. Le decorazioni ed i preziosismi decorativi, ne fanno un oggetto affascinante ed evocativo destinato a diventare un classico senza tempo. L'urna vera e propria, il Cuore, realizzata in fine porcellana lucida, è adagiata su di una base in pietra ceramica con lo stesso motivo decorativo, il tutto assemblato con eleganti perni dorati.

A veiled heart, a POP symbol with a universal meaning, in this solution resolved through the message of the veil which takes care of the given love. The porcelain is modelled like a fabric, forming a delicate drapery from which the plasticity of the heart emerges. The decorations and decorative preciousness make it a fascinating and evocative object destined to become a timeless classic. The real urn, the Heart, made of fine polished porcelain, is placed on a ceramic stone base with the same decorative motif, all assembled with elegant golden pins.



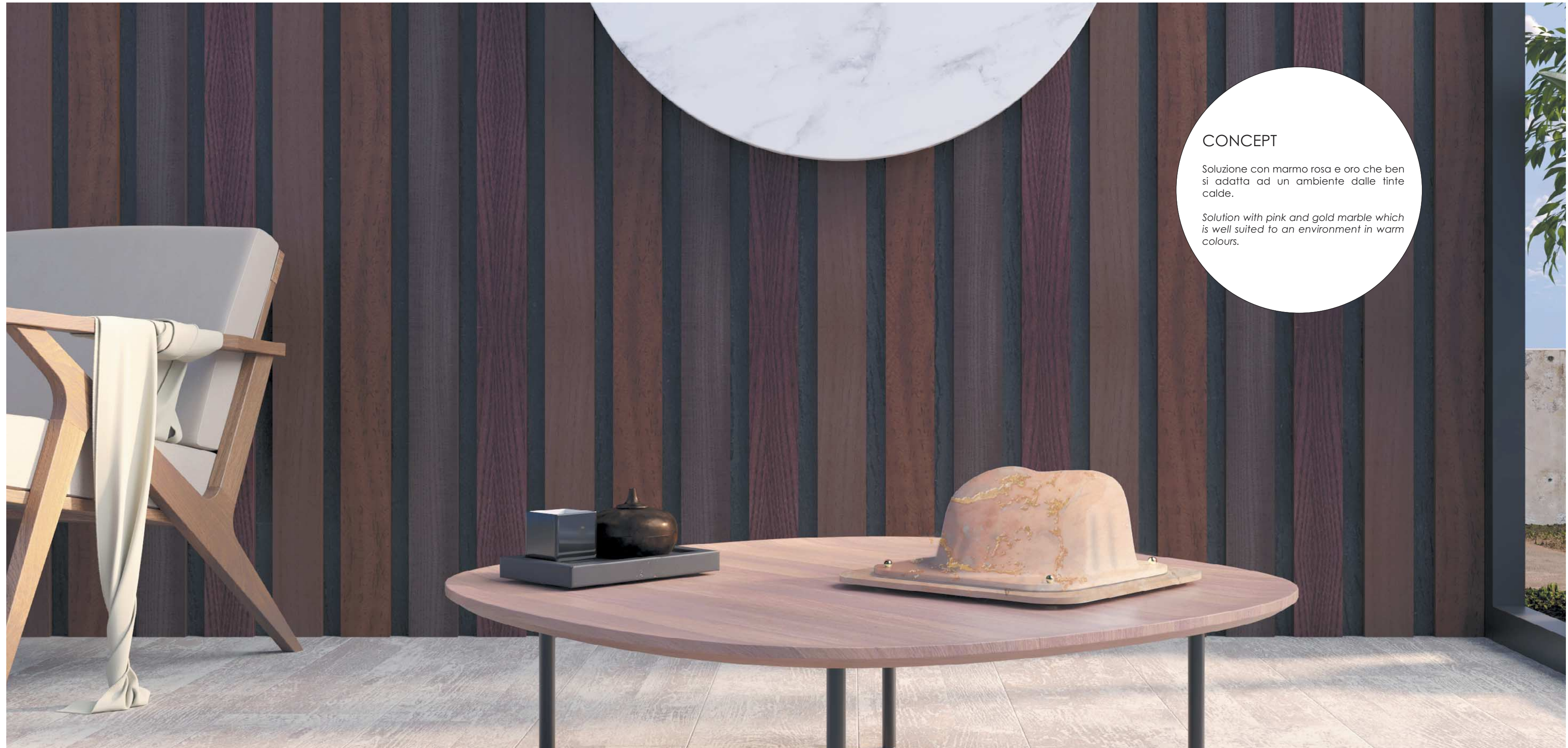

CONCEPT

Soluzione con marmo rosa e oro che ben si adatta ad un ambiente dalle tinte calde.

Solution with pink and gold marble which is well suited to an environment in warm colours.

CONCEPT

Eleganza e carattere in questa versione con marmo nero e oro che crea un suggestivo contrasto con la linearità e la pulizia dell'ambiente circostante.

Elegance and character in this version with black and gold marble which creates a suggestive contrast with the linearity and cleanliness of the surrounding environment.





Immagine prospettica dell'urna Lovely nella decorazione foglie oro.
Perspective image of the Lovely urn in gold leaves decoration.



Lovely - Art. **LOV 01**
• Foglie Oro Zecchino
• Pure Gold Leaves



Lovely - Art. LOV 02

- Marmo Rosa con inserti in Pasta Oro
- Pink Marble with Gold Paste inserts



Lovely - Art. LOV 03

- Marmo Carrara con Venature in Oro Zecchino
- Carrara Marble with Pure Gold veins



Lovely - Art. LOV 04

- Marmo Nero con inserti in Pasta Oro
- Black Marble with Gold Paste inserts



Lovely - Art. LOV 05

- Marmo Tortora con inserti in Pasta Oro
- Brown Marble with Gold Paste inserts



Immagine prospettica dell'urna Lovely nella decorazione marmo carrara con venature oro.
Perspective image of the Lovely urn in carrara marble with pure gold veins decoration.

Classica

Forma che attraversa il tempo grazie al costante rinnovamento nella proposta di nuovi decori. Echi classici sono presenti nelle proposte con preziose marmorizzazioni, mentre più legate ai nostri giorni le alternative che richiamano riproduzioni di texture contemporanee.

A shape which goes through the time thanks to the constant renewal in the proposal of new decorations. Classic echoes are present in the proposals with precious marbling, while the alternatives that recall reproductions of contemporary textures are more linked to our times.





CONCEPT

La raffinatezza della porcellana e l'eleganza di un marmo prezioso per rendere più attuali ed interessanti i nostri spazi living.

The refinement of porcelain and the elegance of a precious marble to make our living spaces more current and interesting.

CONCEPT

La forma sinuosa, ed i preziosismi decorativi, rendono vitali i nuovi trend new classic. Gli ambienti acquisiscono valori estetici mai banali, acquistando valori formali inesplorati.

The sinuous shape and the decorative preciousness make the new Classic trends vital. The environments acquire never banal aesthetic values, acquiring unexplored formal values.





Classica - Art. CLA 01

- Bianco Opaco con bordi Platino
- Mat White with Platinum borders



Classica - Art. CLA 02

- Marmo Carrara con Venature in Oro Zecchino
- Carrara Marble with Pure Gold veins



Classica - Art. CLA 05

- Marmo Arabescato
- Arabesque Carrara Marble



Classica - Art. CLA 06

- Texture Natura a Rilievo con Oro in Pasta
- Nature Texture in Relief with Paste Gold



Classica - Art. CLA 03

- Foglie Platino Mat
- Mat Platinum Leaves



Classica - Art. CLA 04

- Foglie Oro Zecchino
- Pure Gold Leaves



Classica - Art. CLA 07

- Quadrifoglio Avorio/Platino a Rilievo con bordi Platino
- Ivory/Platinum Four-leaf Clover in Relief with Platinum borders



Classica - Art. CLA 08

- Quadrifoglio Tortora/Oro Zecchino a Rilievo con bordi Oro Zecchino
- Brown/Gold Four-leaf Clover in Relief with Pure Gold borders



Classica - Art. CLA 09

- Immagine Floreale con bordi Oro Zecchino
- Floral image with Pure Gold borders



Classica - Art. CLA 10

- Immagine Floreale con bordi Oro Zecchino
- Floral image with Pure Gold borders



Classica - Art. CLA 11

- Marmo Tortora con inserti in Pasta Oro e bordi oro Zecchino
- Brown Marble with Gold Paste inserts with Pure Gold borders



Classica - Art. CLA 12

- Marmo Nero con inserti in Pasta Oro e bordi oro Zecchino
- Black Marble with Gold Paste inserts with Pure Gold borders



Classica - Art. CLA 13

- Texture Floreale Beige a rilievo
- Beige Floral texture in relief



Moon

Concetto che evoca purezza e romanticismo. La forma sferica e la sua lavorazione materica, rimandano all'astro di cui porta il nome. Le sue applicazioni decorative, ci permettono di apprezzarla in più vesti estetiche.

Concept that evokes purity and romance. The spherical shape and its material processing refer to the star whose name it bears. Her decorative applications allow us to appreciate her in more aesthetic guises.



CONCEPT

In questa soluzione, si enfatizza l'effetto materico a rilievo disponibile in molte cromie; la leggerezza della forma sferica acquista grazia ed importanza formale.

In this solution, the relief material effect available in many colors is emphasised; the lightness of the spherical shape acquires grace and formal importance.



CONCEPT

Il Decoro a foglia oro, appare come un elegante meandro iridescente restituendo riflessi di luce. L'ambiente, estremamente contemporaneo, si addice particolarmente alla sua connotazione estetica fornendo inedite contaminazioni.

The gold leaf decoration appears like an elegant iridescent meander, providing reflections of light. The extremely contemporary environment is particularly suited to its aesthetic connotation by providing unprecedented contaminations.



Moon - Art. MOO 01

- Bianco Opaco con bordi Platino
- Mat White with Platinum borders



Moon - Art. MOO 02

- Marmo Arabescato con bordi Platino
- Arabesque Carrara Marble with Platinum borders



Moon - Art. MOO 05

- Marmo Carrara con Venature in Oro Zecchino
- Carrara Marble with Pure Gold veins



Moon - Art. MOO 06

- Polvere di Stelle in Oro Zecchino
- Pure Gold Stardust



Moon - Art. MOO 03

- Foglie Oro Zecchino
- Pure Gold Leaves



Moon - Art. MOO 04

- Foglie Platino Mat
- Mat Platinum Leaves



Moon - Art. MOO 07

- Texture Floreale Beige a rilievo
- Beige Floral texture in relief



Moon - Art. MOO 08

- Texture Natura a Rilievo con Oro in Pasta
- Nature Texture in Relief with Paste Gold



Moon - Art. MOO 09

- Quadrifoglio Tortora/Oro Zecchino a Rilievo
- *Brown/Gold Four-leaf Clover in Relief*



Moon - Art. MOO 10

- Materia Acqua Marina a rilievo
- *Marine Water Material in Relief*



Moon - Art. MOO 11

- Marmo Rosa con inserti in Pasta Oro
- *Pink Marble with Gold Paste inserts*



Moon - Art. MOO 12

- Marmo Tortora con inserti in Pasta Oro
- *Brown Marble with Gold Paste inserts*



Eco

Uno scavo organico su un volume naturale. Il concetto muove da questo aspetto, dall'assoluto equilibrio estetico. La sua forma naturale riesce ad assumere molteplici suggestioni stilistiche.

An organic excavation on a natural volume. The concept starts from this aspect, from absolute aesthetic balance. Its natural shape succeeds to take on multiple stylistic suggestions.





CONCEPT

La foglia platino riveste la forma eco con preziosità e delicatezza. La sua innata originalità si traduce in un risultato estetico dai riflessi mutevoli, ed interessanti.

The platinum leaf covers the eco shape with preciousness and delicacy. Its innate originality translates into an aesthetic result with changing and interesting reflections.



CONCEPT

In questa ambientazione Young Style, vediamo tutta l'efficacia del marmo oro rosa. Il tema classico dell'effetto marmoreo, è qui risolto in chiave attuale, immerso in un ambiente fresco e trendy.

In this Young Style setting, we see all the efficacy of pink and gold marble. The classic theme of the marble effect is here resolved in a modern key, immersed in a fresh and friendly environment.



CONCEPT

...Non stenta di trovare adatta collocazione, anche in ambienti dallo spiccato mood minimal; la sua forma originale esalta il decoro materico.

...It doesn't struggle to find a suitable location, even in environments with a strong minimal mood; its original shape enhances the material decor.



Eco - Art. ECO 01
• Bianco Opaco
• *Mat White*



Eco - Art. ECO 02
• Marmo Arabescato
• *Arabesque Carrara Marble*



Eco - Art. ECO 03
• Foglie Platino Mat
• *Mat Platinum Leaves*



Eco - Art. ECO 04
• Foglie Oro Zecchino
• *Pure Gold Leaves*



Eco - Art. ECO 05
• Materia Acqua Marina a rilievo
• *Marine Water Material in Relief*



Eco - Art. ECO 06

- Texture Floreale Beige a rilievo
- Beige Floral texture in relief



Eco - Art. ECO 07

- Marmo Carrara con venature in Oro Zecchino con Foro in Oro dipinto a mano
- Carrara Marble with Pure Gold veins with handpainted Pure Gold hole



Eco - Art. ECO 10

- Decoro integrale Marmo Rosa con inserti in Pasta Oro
- Full decoration Pink Marble with Gold Paste inserts



Eco - Art. ECO 11

- Polvere di Stelle in Oro Zecchino con Calla Blu Zaffiro e Oro Zecchino
- Pure Gold Stardust with Sapphire Blue and Pure Gold Calla Flower



Eco - Art. ECO 08

- Materia Rosa Corallo a rilievo
- Coral Pink Material in Relief



Eco - Art. ECO 09

- Texture Natura a Rilievo con Oro in Pasta
- Nature Texture in Relief with Paste Gold



Eco - Art. ECO 12

- Decoro integrale Marmo Tortora con inserti in Pasta Oro
- Full decoration Brown Marble with Gold Paste inserts



Eco - Art. ECO 13

- Marmo Nero con inserti in Pasta Oro con Foro in Oro dipinto a mano
- Black Marble with Gold Paste inserts with handpainted Pure Gold hole



Maya

Concept design che porta il pensiero ai formalismi Maya. L'oggetto è dotato di uno scasso sulla sommità che permette l'eventuale collocazione di una piantina o altro oggetto. Utilizzabile efficacemente anche in purezza. La voluta in bassorilievo che la cinge, è un delizioso tramite tra scultura e decorazione cromatica.

Design concept which brings thought to Mayan formalisms. The object is equipped with a cutout on the top which allows the possible placement of a plant or other object. Can also be used effectively in purity. The bas-relief scroll that surrounds it is a delightful link between sculpture and chromatic decoration.



CONCEPT

...collocata su consolle contemporanee, tra oggetti che richiamano alla memoria, il ricordo, o semplicemente tra gli oggetti che amiamo.

...placed on contemporary consoles, among objects that recall memories, or simply among the objects we love.





Maya - Art. MAY 01

- Bianco Opaco
- Mat White



Maya - Art. MAY 02

- Marmo Carrara con venature in Oro Zecchino
- Carrara Marble with Pure Gold veins



Maya - Art. MAY 03

- Foglie Platino Mat
- Mat Platinum Leaves



Maya - Art. MAY 04

- Foglie Oro Zecchino
- Pure Gold Leaves



Maya - Art. MAY 05

- Marmo Rosa con inserti in Pasta Oro
- Pink Marble with Gold Paste inserts



Maya - Art. MAY 06

- Texture Floreale Beige a rilievo
- Beige Floral texture in relief



Maya - Art. MAY 07

- Marmo Tortora con inserti in Pasta Oro
- Brown Marble with Gold Paste inserts



Maya - Art. MAY 08

- Materia Rosa Corallo a rilievo
- Coral Pink Material in Relief



Maya - Art. MAY 09

- Materia Acqua Marina a rilievo
- Marine Water Material in Relief

Immagine dall'alto della Maya con decorazione marmo carrara con venaure oro.
Esempio con pianta in vaso alloggiata all'interno del contenitore superiore.

Top view of the Maya in carrara marble decoration with gold veins.
Example with a potted plant placed inside the top container.





Sfera

Alternativa suggestione evocata dalla forma sferica; La decorazione plastica tornita ad arte, conferisce all'oggetto una particolare caratteristica scultorea, sensibile alla rifrazione della luce. Poliedrica e capace di sostenere variegata tematiche decorative, dalle emozionali tinte applicate a mano ai temi floreali evergreen fino alle più contemporanee texture materiche.

An alternative suggestion evoked by the spherical shape, the artistically turned plastic decoration gives to the object a particularity sculptural characteristic, sensitive to the refraction of light. Multifaceted and capable of supporting varied decorative and emotional themes dyes applied by hand from evergreen floral themes to the most contemporary material textures.

CONCEPT

L'oro diventa assoluto protagonista in questa versione, ma rimane al servizio della forma, sicuro pass part tout tra ambiente contemporaneo e classicità.

Gold becomes the absolute protagonist in this version, but remains at the service of the form, a sure pass part tout between contemporary and classic environments.





Sfera - Art. SFE 01

- Bianco Opaco con bordo Platino
- Mat White with Platinum Border



Sfera - Art. SFE 02

- Oro Zecchino Mat dipinto a mano
- Mat Pure Gold painted by hand



Sfera - Art. SFE 03

- Colore Ruggine Artistico dipinto a mano
- Artistic Rust color hand painted

Le immagini sono puramente indicative in quanto essendo decorata a mano ogni urna è diversa dall'altra.

The images are purely indicative because each urn is handpainted so each one is different from the other.



Sfera - Art. SFE 04

- Colore Smeraldo Artistico dipinto a mano
- Artistic Emerald color hand painted

Le immagini sono puramente indicative in quanto essendo decorata a mano ogni urna è diversa dall'altra.

The images are purely indicative because each urn is handpainted so each one is different from the other.



Sfera - Art. SFE 05

- Marmo Carrara con venature in Oro Zecchino
- Carrara Marble with Pure Gold veins



Sfera - Art. SFE 06

- *Materia Acqua Marina a rilievo*
- *Marine Water Material in Relief*



Sfera - Art. SFE 07

- *Materia Sabbia del Sahara a rilievo*
- *Sahara Sand Material in Relief*



Sfera - Art. SFE 08

- *Materia Rosa Corallo a rilievo*
- *Coral Pink Material in Relief*



Sfera - Art. SFE 09

- *Materia Terra Titanio a rilievo*
- *Titanium Earth material in Relief*





Sfera - Art. SFE 10

- Immagine Floreale Orchidee
- *Orchids Floral image*



Sfera - Art. SFE 11

- Roselline stilizzate Avorio con inserti Rame e Oro Zecchino
- *Stylized ivory roses with copper and pure gold inserts*



Sfera - Art. SFE 12

- Fiori metal argento
- *Metalized silver flowers*



Sfera - Art. SFE 13

- Fiori metal oro
- *Metalized Gold flowers*



Sfera - Art. SFE 14

- Calle Blu Zaffiro con particolari in Oro Zecchino
- *Blu Sapphire Calla Flowers with details in Pure Gold*



Planet

Un pianeta in mutazione, cinto da una fascia che ne rompe il plasticismo. Forma pura, semplice, appropriata a tutti gli interiors. Concetto minimal architettonico, la sua natura plastica, in perfetto equilibrio tra purezza, materia, organicità. Matericità ed originali cromie, ne trasformano i tratti in gesti estetici.

A changing planet, surrounded by a band which breaks its plasticity. Pure, simple shape, appropriate for all interiors. Minimal architectural concept, its plastic nature, in perfect balance between purity, matter, organicity. Materiality and original colors transform the features into aesthetic gestures.

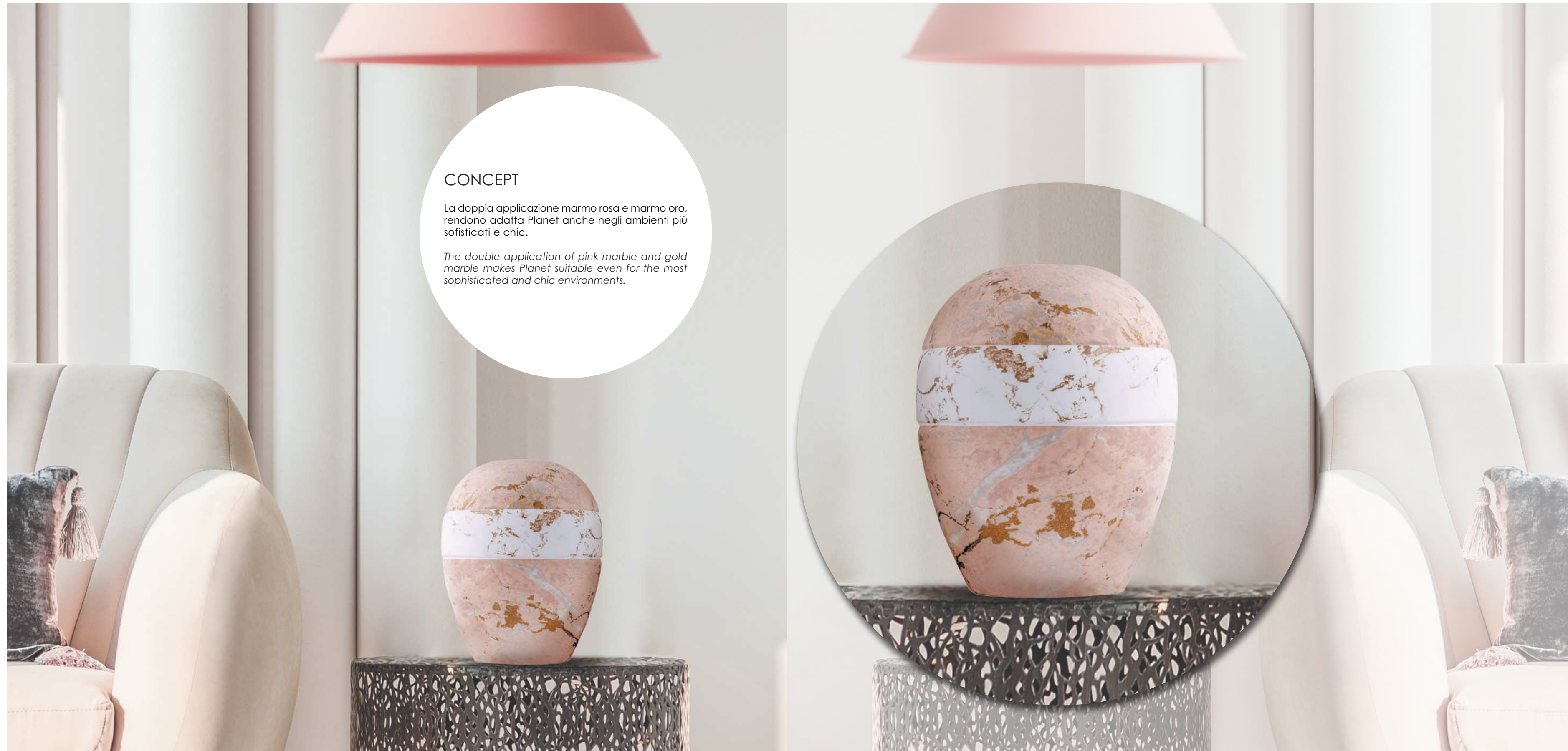

CONCEPT

La doppia applicazione marmo rosa e marmo oro, rendono adatta Planet anche negli ambienti più sofisticati e chic.

The double application of pink marble and gold marble makes Planet suitable even for the most sophisticated and chic environments.

CONCEPT

Il candore del marmo e le mazzature dorate, si fondono perfettamente in quest'ambiente Shaby. Il preziosismo delicato ne enfatizza la versatilità e l'eleganza.

The whiteness of the marble and the golden marbling blend perfectly in this Shaby environment. The delicate preciousness emphasizes its versatility and elegance.





Planet - Art. PLA 01

- Polvere di Stelle in Oro Zecchino
- Pure Gold Stardust



Planet - Art. PLA 02

- Marmo Carrara con venature in Oro Zecchino
- Carrara Marble with Pure Gold veins



Planet - Art. PLA 03

- Combinazione di Marmi Bianco/Tortora con inserti in Pasta Oro
- Combination of White/Brown Marble with Gold Paste inserts



Planet - Art. PLA 04

- Texture Floreale Beige a rilievo
- Beige Floral texture in relief



Planet - Art. PLA 05

- Materia Terra di Titanio a Rilievo con fascia in Lamina di Platino Mat applicata a mano
- Titanium Earth material in Relief with matt platinum foil applied by hand on the strip



Planet - Art. PLA 06

- Fascia con Immagine Floreale
- Strip with Floral image



Planet - Art. PLA 07

- Fascia con Immagine Floreale
- Strip with Floral image



Planet - Art. PLA 10

- Materia Acqua Marina a Rilievo
- Marine Water Material in Relief



Planet - Art. PLA 11

- Materia Rosa Corallo a Rilievo
- Coral Pink Material in Relief



Planet - Art. PLA 08

- Fascia con Immagine Floreale
- Strip with Floral image



Planet - Art. PLA 09

- Fascia con Immagine Floreale
- Strip with Floral image



Planet - Art. PLA 12

- Combinazione di Marmi Rosa/Bianco con inserti in Pasta Oro
- Combination of Pink/White Marble with Gold Paste inserts



Planet - Art. PLA 13

- Combinazione di Marmi Tortora/Bianco con inserti in Pasta Oro
- Combination of Brown/White Marble with Gold Paste inserts

Exagon

Archetipo architettonico di assoluta forza evocativa. Un volume esagonale suddiviso da modanature neoclassiche. Interpretazione del battistero simbolo di nascita e rinascita. Ne esaltano le forme i numerosi cromatismi e pattern tutto a servizio della sua efficacia evocativa.

Architectural archetype with absolute evocative power. A hexagonal volume divided by neoclassical mouldings. Interpretation of the baptistery symbol of birth and rebirth. The numerous colors and patterns enhance its shapes, all serving its evocative effectiveness.





CONCEPT

Con questa applicazione il neoclassico si sposa con l'art nouveau. Una decorazione a foglia policroma veste EXAGON di una nuova luce estetica. Le modanature lasciate in pura porcellana, ne marcano il concetto architettonico.

With this application neoclassicism marries art nouveau. A polychrome leaf decoration dresses EXAGON in a new aesthetic light. The moldings left in pure porcelain mark the architectural concept.

Exagon



CONCEPT

Exagon in un'inesplorata veste lapidea. Marmo marrone con intarsi oro, può accostarsi anche agli ambienti shaby chic con assoluta disinvoltura.

Exagon in an unexplored stone guise. Brown marble with gold inlays, it can also be combined with shaby chic environments with absolute ease.



Exagon - Art. EXA 01

- Bianco Opaco con bordi Oro Zecchino
- Mat White with Pure Gold Borders



Exagon - Art. EXA 02

- Marmo Carrara con venature in Oro Zecchino
- Carrara Marble with Pure Gold veins



Exagon - Art. EXA 05

- Quadrifoglio Avorio/Platino a Rilievo con bordi Platino
- Ivory/Platinum Four-leaf Clover in Relief with Platinum borders



Exagon - Art. EXA 06

- Quadrifoglio Tortora/Oro Zecchino a Rilievo con bordi Oro Zecchino
- Brown/Gold Four-leaf Clover in Relief with Pure Gold borders



Exagon - Art. EXA 03

- Foglie Oro Zecchino
- Pure Gold Leaves



Exagon - Art. EXA 04

- Foglie Platino Mat
- Mat Platinum Leaves



Exagon - Art. EXA 07

- Materia Rosa Corallo a Rilievo
- Coral Pink Material in Relief



Exagon - Art. EXA 08

- Materia Acqua Marina a Rilievo
- Marine Water Material in Relief



Exagon - Art. EXA 09

- Marmo Tortora con inserti in Pasta Oro
- Brown Marble with Gold Paste inserts



Exagon - Art. EXA 10

- Marmo Rosa con inserti in Pasta Oro
- Pink Marble with Gold Paste inserts



Exagon - Art. EXA 13

- Immagine Angelo con bordi Oro Zecchino
- Angel image with Pure Gold borders



Exagon - Art. EXA 14

- Immagine Giudizio Universale con bordi Oro Zecchino
- Last Judgment image with Pure Gold borders



Exagon - Art. EXA 11

- Immagine Floreale con bordi Oro Zecchino
- Floral image with Pure Gold borders



Exagon - Art. EXA 12

- Texture Natura a Rilievo con Oro in Pasta
- Nature Texture in Relief with Paste Gold



Exagon - Art. EXA 15

- Immagine Madonna con Bambino con bordi Oro Zecchino
- Our Lady with Child image with Pure Gold borders



Exagon - Art. EXA 16

- Immagine Angeli con bordi Oro Zecchino
- Angels image with Pure Gold borders



Liberty

In questo concept, vediamo esprimersi le avanguardie fine 800. Mai banale sempre attuale un classico che non ha finito ancora di esprimersi. Equilibri geometrici misurati demarcati da originali decorazioni.

In this concept, we see the avant-gardes of the late 19th century express themselves. Never banal, always current, a classic that has not yet finished expressing itself. Measured geometric balances demarcated by original decorations.



CONCEPT

Il marmo marrone oro immerso in un ambiente contemporaneo. La forma elegante che assorbe i contrasti, rilasciando un impatto visivo inedito.

Golden brown marble nestled in a contemporary setting. The elegant shape that absorbs contrasts, releasing a new visual impact.



CONCEPT

Gli ambienti più classici, sostengono appieno l'eleganza Liberty. Il decoro foglia oro si accosta in maniera del tutto naturale con le scelte più tradizionalmente eleganti.

The more classic environments fully support Liberty elegance. The gold leaf decoration combines in a completely natural way with the more traditionally elegant choices.



Liberty - Art. LIB 01

- Bianco Opaco con bordi Oro
- *Mat White with Pure Gold Borders*



Liberty - Art. LIB 02

- Texture Floreale Beige a rilievo
- *Beige Floral texture in relief*



Liberty - Art. LIB 05

- Marmo Carrara con venature in Oro Zecchino e particolari Oro dipinto a mano
- *Carrara Marble with Pure Gold veins and hand-painted Gold details*



Liberty - Art. LIB 06

- Polvere di Stelle in Oro Zecchino e particolari Oro dipinto a mano
- *Pure Gold Stardust and hand-painted Gold details*



Liberty - Art. LIB 03

- Foglie Platino Mat
- *Mat Platinum Leaves*



Liberty - Art. LIB 04

- Foglie Oro Zecchino
- *Pure Gold Leaves*



Liberty - Art. LIB 07

- Marmo Rosa con inserti in Pasta Oro e particolari Oro dipinto a mano
- *Pink Marble with Gold Paste inserts and hand-painted Gold details*



Liberty - Art. LIB 08

- Marmo Tortora con inserti in Pasta Oro e particolari Oro dipinto a mano
- *Brown Marble with Gold Paste inserts and hand-painted Gold details*



Liberty - Art. LIB 09

- Immagine Floreale con bordi Oro Zecchino
- *Floral image with Pure Gold borders*



Liberty - Art. LIB 10

- Immagine Floreale con bordi Oro Zecchino
- *Floral image with Pure Gold borders*



Liberty - Art. LIB 13

- Calle Blu Zaffiro con particolari in Oro Zecchino e bordo Oro Zecchino su coperchio
- *Flowers Blu Sapphire with Pure Gold details and Pure Gold border on the lid*



Liberty - Art. LIB 14

- Immagine Angelo con bordi Platino
- *Angel image with Platinum borders*



Liberty - Art. LIB 11

- Texture Natura a Rilievo con Oro in Pasta e particolari in Oro dipinto a mano
- *Nature Texture in Relief with Paste Gold and hand-painted Gold details*



Liberty - Art. LIB 12

- Immagine Floreale con bordi Oro Zecchino
- *Floral image with Pure Gold borders*



Liberty - Art. LIB 15

- Immagine Cristo con bordi Platino
- *Christ image with Platinum borders*



Liberty - Art. LIB 16

- Immagine Madonna con bordi Platino
- *Our Lady image with Platinum borders*

Scheda tecnica - Technical data sheet

Princess

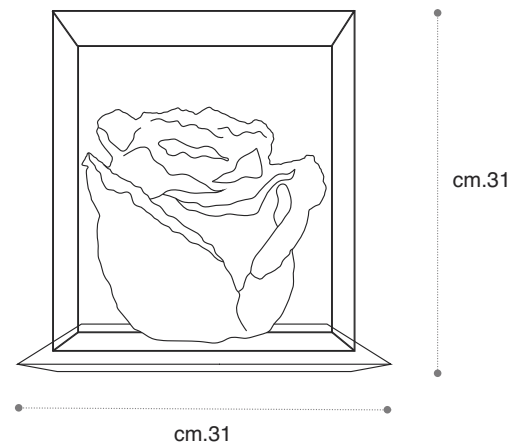

Caratteristiche Tecniche - Technical features

Materia Rosa : porcellana lucida
 Struttura in acciaio color antracite
 Base in legno laccato nero opaco
 Capacità cm³ 4700
 Dimensione della Rosa cm. 26 H x 21L
 Chiusura ermetica in alluminio dal basso
 Provvista di sacchetto ignifugo per le ceneri

*Rose material : glossy porcelain
 Anthracite colored steel structure
 Base in matt black lacquered wood
 Capacity cm³ 4700
 Rose Dimension cm 26H x 21L
 Hermetic aluminum closure on the bottom
 Supplied with fireproof bag for ashes*

Decorazioni disponibili - Available decorations

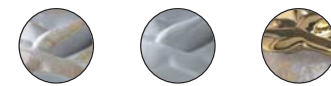

Classica

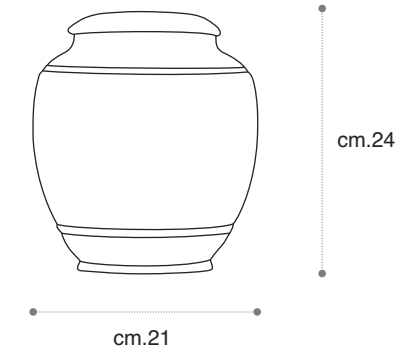

Caratteristiche Tecniche - Technical features

Materia : porcellana opaca
 Capacità cm³ 5000
 Chiusura ermetica in alluminio dall'alto
 Provvista di sacchetto ignifugo per le ceneri

*Material : matt porcelain
 Capacity cm³ 5000
 Hermetic aluminum closure on the top
 Supplied with fireproof bag for ashes*

Decorazioni disponibili - Available decorations

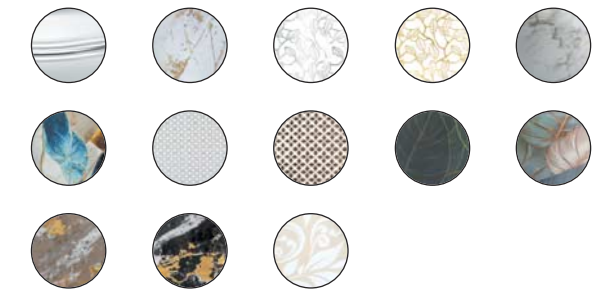

Moon

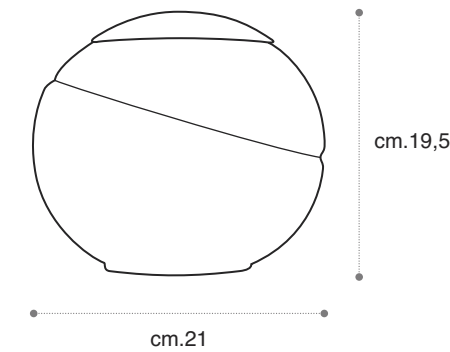

Caratteristiche Tecniche - Technical features

Materia : porcellana opaca
 Capacità cm³ 4000
 Chiusura ermetica in alluminio dall'alto
 Provvista di sacchetto ignifugo per le ceneri

*Material : matt porcelain
 Capacity cm³ 4000
 Hermetic aluminum closure on the top
 Supplied with fireproof bag for ashes*

Decorazioni disponibili - Available decorations

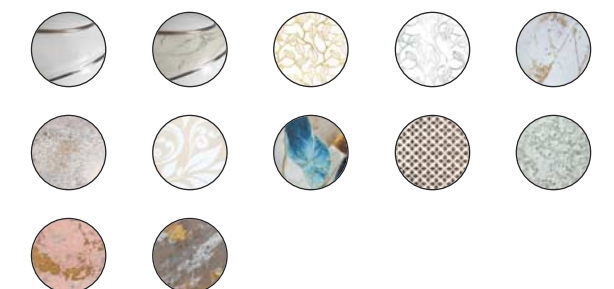

Picture

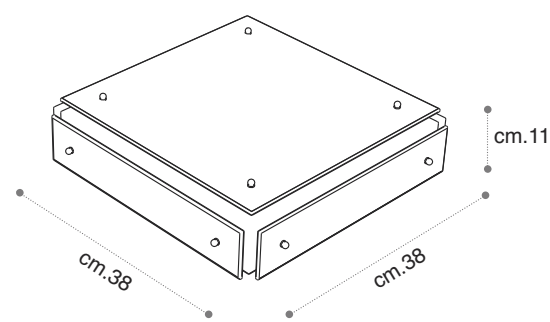

Caratteristiche Tecniche - Technical features

Materia urna: metallo laccato in oro opaco
 Pannelli esterni in pietra ceramica decorata
 Capacità cm³ 8000
 Chiusura ermetica in alluminio dal basso
 Provvista di sacchetto ignifugo per le ceneri

*Urn material : matt gold lacquered metal
 External panels in decorated ceramic stone
 Capacity cm³ 8000
 Hermetic aluminum closure on the bottom
 Supplied with fireproof bag for ashes*

Decorazioni disponibili - Available decorations



- L'urna Picture è predisposta sia per l'applicazione a parete che da appoggio, pertanto viene fornita con entrambi kit di fissaggio.

- The Picture urn is designed for both wall and horizontal application, therefore it is supplied with both fixing kits.

Eco

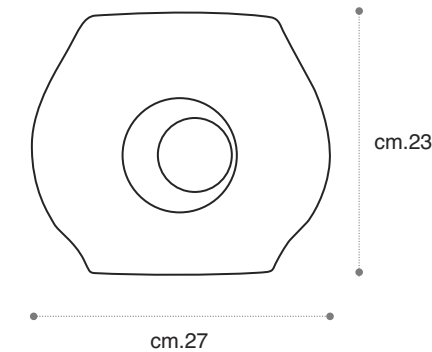

Caratteristiche Tecniche - Technical features

Materia : porcellana opaca
 Capacità cm³ 3000
 Chiusura ermetica in alluminio dal basso
 Provvista di sacchetto ignifugo per le ceneri

*Material : matt porcelain
 Capacity cm³ 3000
 Hermetic aluminum closure on the bottom
 Supplied with fireproof bag for ashes*

Decorazioni disponibili - Available decorations

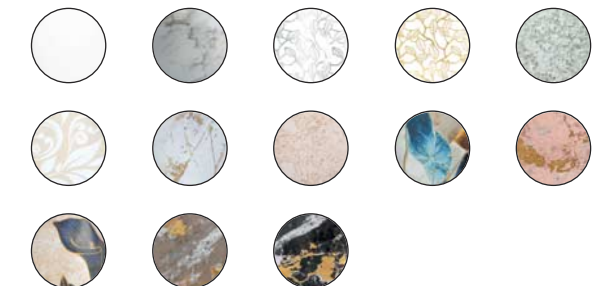

Lovely

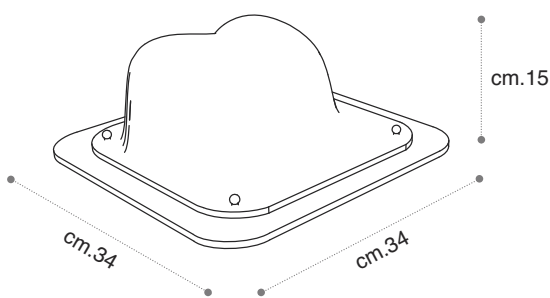

Caratteristiche Tecniche - Technical features

Materia Cuore : porcellana lucida
 Base in pietra ceramica decorata
 Capacità cm³ 4000
 Chiusura ermetica in alluminio dal basso
 Provvista di sacchetto ignifugo per le ceneri

*Heart material : glossy porcelain
 Decorated ceramic stone base
 Capacity cm³ 4000
 Hermetic aluminum closure on the bottom
 Supplied with fireproof bag for ashes*

Decorazioni disponibili - Available decorations



Maya

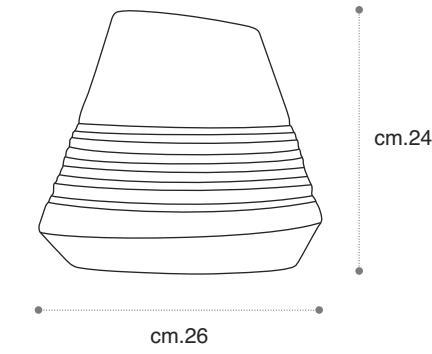

Caratteristiche Tecniche - Technical features

Materia : porcellana opaca
 Capacità cm³ 4600
 Chiusura ermetica in alluminio dal basso
 Provvista di sacchetto ignifugo per le ceneri

*Material : matt porcelain
 Capacity cm³ 4600
 Hermetic aluminum closure on the bottom
 Supplied with fireproof bag for ashes*

Decorazioni disponibili - Available decorations

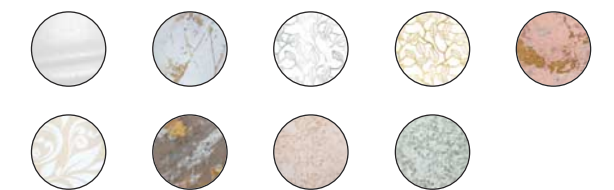

Sfera

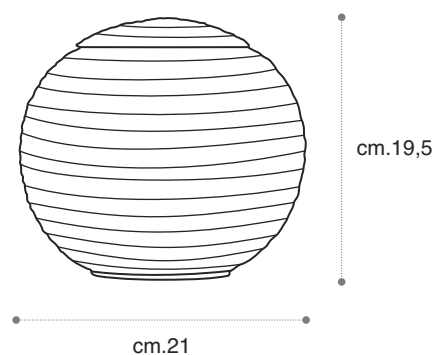

Caratteristiche Tecniche - Technical features

Materia : porcellana opaca
 Capacità cm³ 4000
 Chiusura ermetica in alluminio dall'alto
 Provvista di sacchetto ignifugo per le ceneri

*Material : matt porcelain
 Capacity cm³ 4000
 Hermetic aluminum closure on the top
 Supplied with fireproof bag for ashes*

Decorazioni disponibili - Available decorations

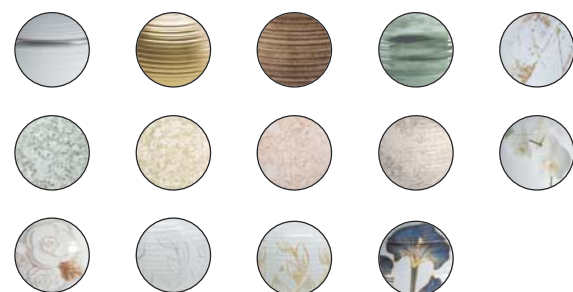

Planet

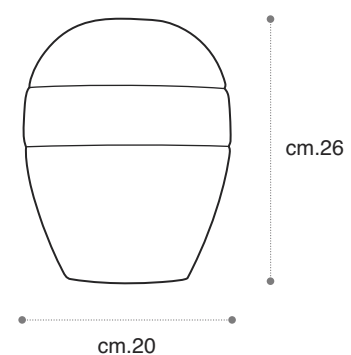

Caratteristiche Tecniche - Technical features

Materia : porcellana opaca
 Capacità cm³ 5500
 Chiusura ermetica in alluminio dal basso
 Provvista di sacchetto ignifugo per le ceneri

*Material : matt porcelain
 Capacity cm³ 5500
 Hermetic aluminum closure on the bottom
 Supplied with fireproof bag for ashes*

Decorazioni disponibili - Available decorations



Exagon

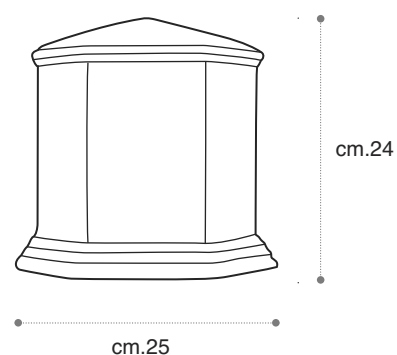

Caratteristiche Tecniche - Technical features

Materia : porcellana opaca
 Capacità cm³ 5000
 Chiusura ermetica in alluminio dal basso
 Provvista di sacchetto ignifugo per le ceneri

*Material : matt porcelain
 Capacity cm³ 5000
 Hermetic aluminum closure on the bottom
 Supplied with fireproof bag for ashes*

Decorazioni disponibili - Available decorations



Liberty

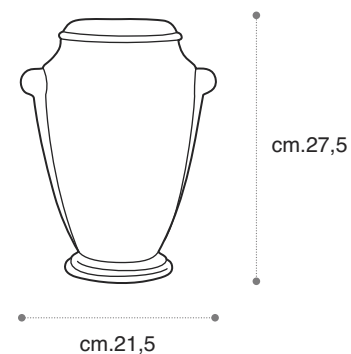

Caratteristiche Tecniche - Technical features

Materia : porcellana opaca
 Capacità cm³ 3500
 Chiusura ermetica in alluminio dall'alto
 Provvista di sacchetto ignifugo per le ceneri

*Material : matt porcelain
 Capacity cm³ 3500
 Hermetic aluminum closure on the top
 Supplied with fireproof bag for ashes*

Decorazioni disponibili - Available decorations

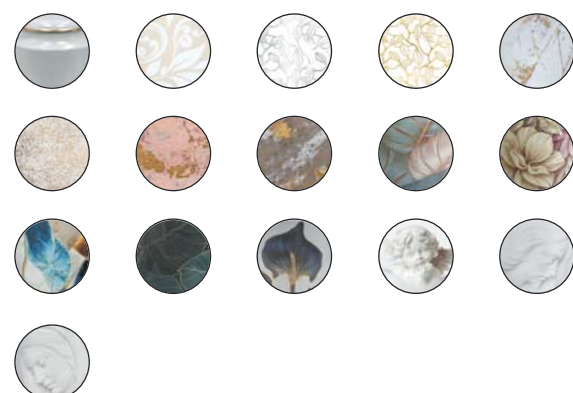

Raffinata Porcellana ad alta resistenza.
 Design Italiano di assoluta efficacia.
 Preziosi motivi decorativi adatti a qualsiasi contesto.
 Resistenza a qualsiasi agente atmosferico.
 Versatilità nell'impiego sia indoor che outdoor.

*Refined high resistance porcelain.
 Absolutely effective Italian design.
 Precious decorative motifs suitable for any context.
 Resistance to any atmospheric agent.
 Versatility in both indoor and outdoor use.*

1° Fuoco

Ceramica a 1° fuoco (1000°) decorata con colori a freddo



Fornatura



Biscottatura



Decorazione con colori a freddo



2° Fuoco

Ceramica smaltata con smalti e colori ceramici e cotta a 2° fuoco (900°)



Smaltatura dei biscotti



decoro



2ª cottura



3° Fuoco

Ceramica smaltata con smalti e colori ceramici cotta a 2° fuoco (900°) con aggiunta di lustri oro o platino al 10% e cotta in 3° fuoco a 780°



decoro



3ª Cottura



Biodegradabile 

Cotte ad una temperatura inferiore alla fase di vetrificazione. Dipinte con colori naturali a freddo, si degradano in acqua in meno di un'ora.



Come ordinare:

Selezionare il codice articolo ad es. UR1 ed il codice colore desiderato ad es. 78

Tutti i decori/colori visibili nel catalogo possono essere eseguiti nelle vari modelli/forme di urne.

How to order:

Select the item code, e.g. UR1 and the desired color code, e.g. 78

All the decorations / colors visible in the catalog can be executed in the various shape of URNS.



Forniamo in ogni modello il sacco per le ceneri resistente alle alte temperature. Alcuni modelli hanno l'apertura da sopra, altri da sotto con tappo in lamiera zincata e viti di fissaggio. Altre ancora hanno il coperchio in ceramica sigillabile con il silicone

We supply in each model the bag for the ash resistant to high temperatures. Some models have the opening from above, others from underneath with galvanized steel plug and screws fixing. Others still have the lid in ceramics sealable with silicone

Urne cinerarie
Catalogo 2024



500 3° fuoco



501 3° fuoco



502 3° fuoco



503 3° fuoco



504 1° fuoco



505 1° fuoco



506 1° fuoco



507 1° fuoco

UR 500 - H17 X L40 X P21 - Lt 6



1100 3° fuoco



1101 1° fuoco



1102 3° fuoco



1104 1° fuoco



1105 1° fuoco



UR FIAT 1100 - H16 X L18X P35 - Lt 5



190 3° fuoco



191 3° fuoco



192 2° fuoco



194 2° fuoco



193 2° fuoco





201 3° fuoco



202 3° fuoco



203 2° fuoco



204 1° fuoco

UR BARCA - H38 X L30 X P21 - Lt 5,5



211 3° fuoco



210 3° fuoco



212 3° fuoco



213 2° fuoco



118/N 2° fuoco



119/N 2° fuoco



117/N 2° fuoco



121/N 2° fuoco

UR SASSO - H19 X L30 X P28 - Lt 5



115/F 3° fuoco



115/FP 3° fuoco



116/FP 3° fuoco



116/F 3° fuoco

UR-AFARF02 - H5 X L14X P8 - Lt 0,2



119/F 2° fuoco



Attacco a muro incluso,
pedistallo a richiesta



117/F 3° fuoco



118/F 3° fuoco

UR FARFALLA - H16 X L28 X P38 - Lt 6



122 3° fuoco



123 3° fuoco



124 3° fuoco



125 1° fuoco



126 1° fuoco



127 1° fuoco



123-B 3° fuoco



127-B 1° fuoco



125-B 1° fuoco



N 1° fuoco



C 1° fuoco



I 1° fuoco



J 1° fuoco



M 1° fuoco

UR FBALL B - H25 Ø 20 - Lt 4



140/C 3° fuoco

UR CASCO - H25xL23xP30 - Lt 8



141/C 3° fuoco



142/C 1° fuoco



T 1° fuoco

UR SFERA - Ø25 - Lt 7



8/B 1° fuoco



15/B 1° fuoco

BIODEGRADABILI

si degradano in acqua in meno di un'ora
Prodotte con argilla di cava e colori biologici



78 1° fuoco



79 1° fuoco



80 1° fuoco

UR CUORE - H14 X L30 X P29 - Lt 5



38/N 1° fuoco



37/N 1° fuoco



36/N 1° fuoco

UR 10 - Ø20 X L30 - Lt 5



150 3° fuoco



152 3° fuoco



151 3° fuoco



153 3° fuoco



154 3° fuoco

UR UOVO - H25 X L25 X P35 - Lt 9



85 3° fuoco



86 3° fuoco

Attacco a muro incluso,
pedistallo a richiesta



87 3° fuoco



114/T 3° fuoco

UR STELLA - H12 X L39 - Lt 5



3° fuoco (5)



3° fuoco (4)



2° fuoco (211)



3° fuoco (83)

UR FOTO - H34 X L44 X P11 - Lt 5
UR FOTOX2 - H34 X L44 X P15 - Lt 5+5



3° fuoco (84)



3° fuoco (128/1)



3° fuoco (92/F)

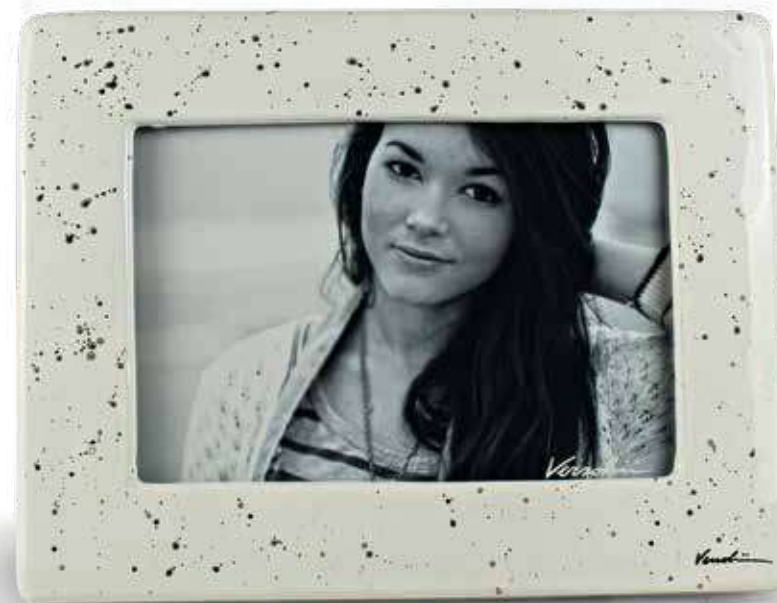

3° fuoco (210)

UR FOTO - H34 X L44 X P11 - Lt 5
UR FOTOX2 - H34 X L44 X P15 - Lt 5+5



1 3° fuoco



3 3° fuoco



2 3° fuoco

In appoggio o da appendere, sia in orizzontale che in verticale



135 3° fuoco

UR FOTO - H34 X L44 X P11 - Lt 5
UR FOTOX2 - H34 X L44 X P15 - Lt 5+5



133 3° fuoco



134 3° fuoco

Tutti i modelli sono disponibili con cassetta singola o doppia

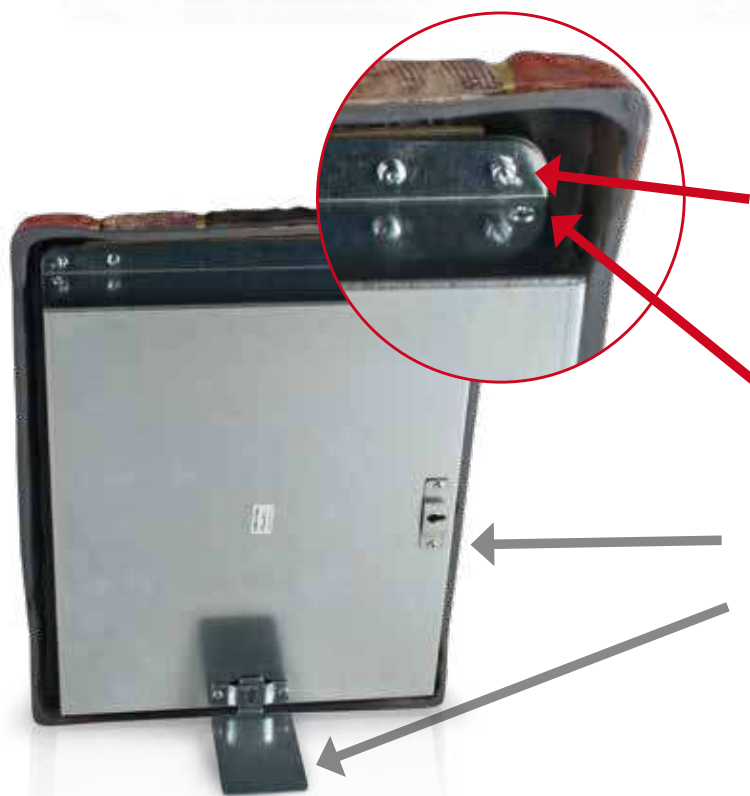

4 viti a croce fissano la cornice in ceramica alla cassetta in metallo
 4 dadi fissano il coperchio della cassetta in metallo attaccaglia a muro o per inserimento piedistallo, in verticale o in orizzotale



UR FOTO - H34 X L44 X P11 - Lt 5
UR FOTOX2 - H34 X L44 X P15 - Lt 5+5



88 2° fuoco



89 2° fuoco



90 2° fuoco



91 2° fuoco



113 BIODEGRADABILE 



Attacco a muro incluso,
pedistallo a richiesta



45 3° fuoco



114 3° fuoco



170 BIODEGRADABILE 



46 3° fuoco



141 3° fuoco



142 3° fuoco



73 3° fuoco



92 3° fuoco



145 3° fuoco



Attacco a muro incluso,
pedistallo a richiesta



128 3° fuoco

UR CUORE - H14 X L30 X P29 - Lt 5



72 3° fuoco



75 3° fuoco



71 3° fuoco



76 3° fuoco



74 3° fuoco



140 2° fuoco

UR CUORE - H14 X L30 X P29 - Lt 5



130 3° fuoco



129 3° fuoco



146 3° fuoco



147 3° fuoco



143 1° fuoco



144 1° fuoco



148 2° fuoco



149 2° fuoco



180 2° fuoco



181 2° fuoco



182 3° fuoco



183 3° fuoco

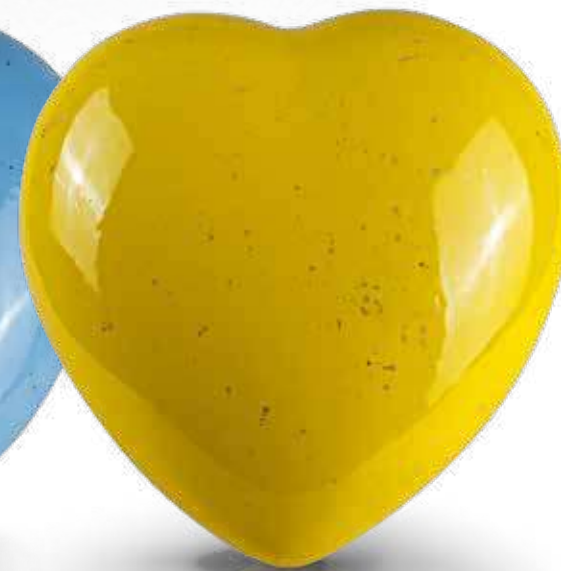

184 3° fuoco

UR CUORE - H14 X L30 X P29 - Lt 5



69 3° fuoco



68 3° fuoco



70 3° fuoco



Attacco a muro incluso,
pedistallo a richiesta



92/1 3° fuoco



98 3° fuoco



92/2 3° fuoco



114/S 3° fuoco

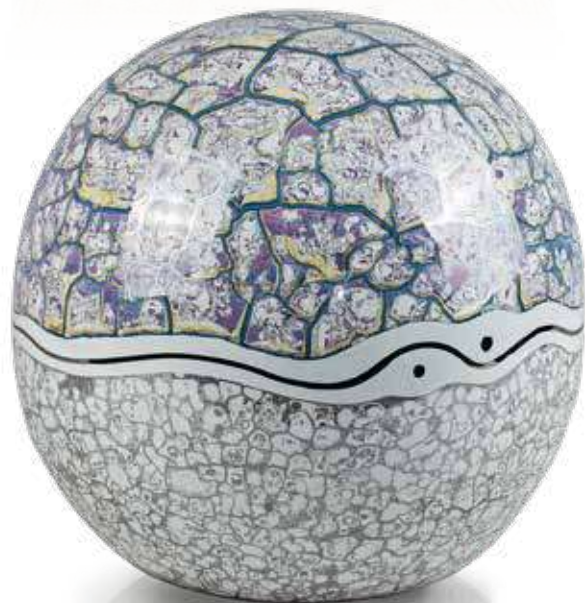

61 3° fuoco



58 3° fuoco



59 1° fuoco



184 2° fuoco



185 2° fuoco



47 3° fuoco



182 2° fuoco



183 2° fuoco



48 3° fuoco

UR SFERA - Ø25 - Lt 7

UR PIRAMIDE - H25 X L26 X P26 - Lt 5



94 3° fuoco



95 3° fuoco



92/3 3° fuoco



49 3° fuoco



49 3° fuoco



97 1° fuoco

UR PIRAMIDE - H25 X L26 X P26 - Lt 5



52 3° fuoco

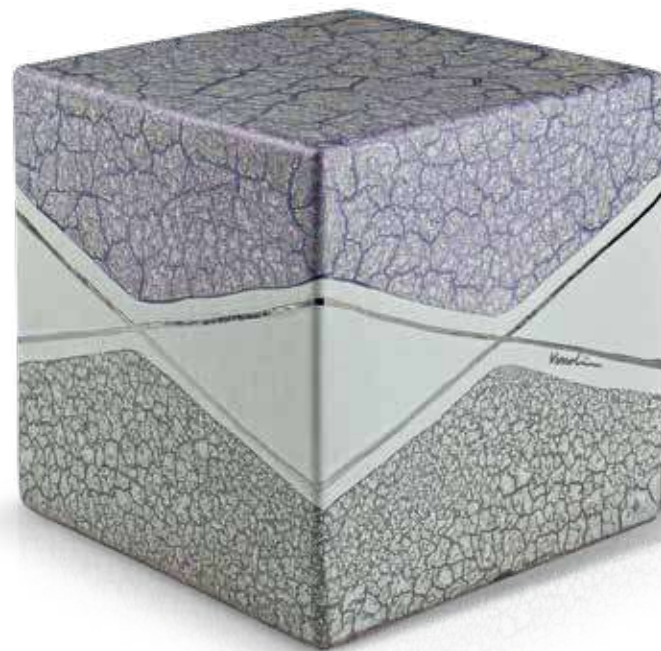

55 3° fuoco



54 3° fuoco



100 3° fuoco



53 3° fuoco

UR CUBO - H20 X L20 X P20- Lt 5



51 3° fuoco



186 3° fuoco

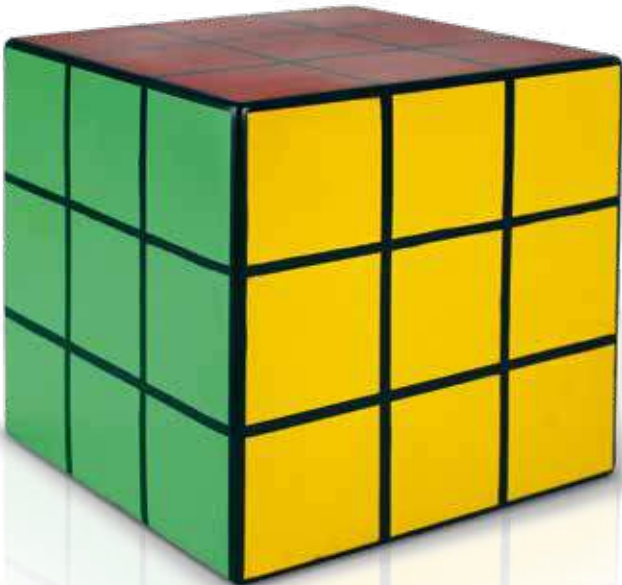

188 1° fuoco



187 2° fuoco

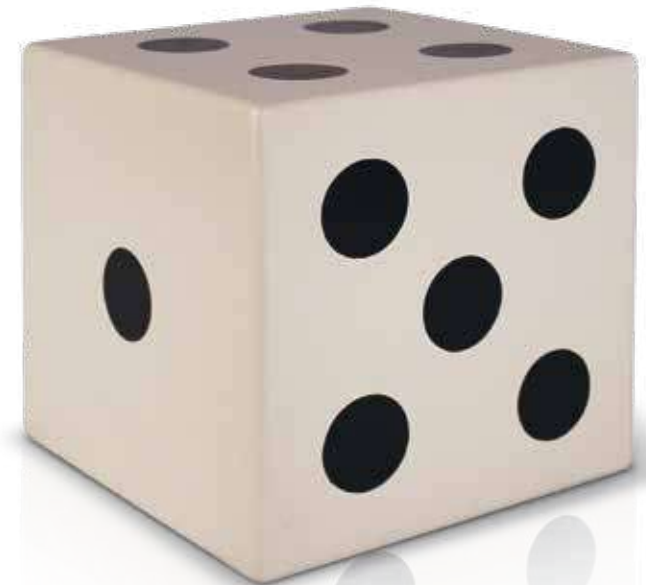

188 1° fuoco

UR CUBO - H20 X L20 X P20- Lt 5



160 3° fuoco



161 3° fuoco



162 2° fuoco



UR MANHATTAN - H32 X L30 X P23- Lt 5



163 3° fuoco



164 3° fuoco

UR MANHATTAN - H32 X L30 X P23- Lt 5



39 3° fuoco

58 3° fuoco

92/F 3° fuoco

56 3° fuoco

Vaso ad incastro

UR FIORI - Ø24 X H44- Lt 5



98/V 3° fuoco



43 2° fuoco



44 3° fuoco

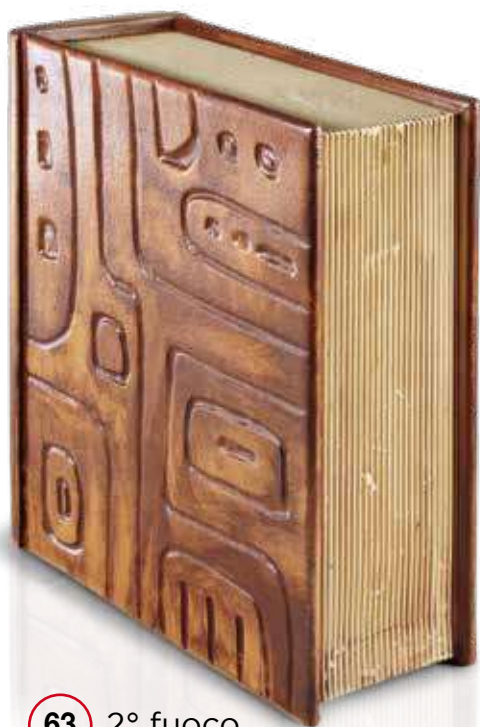

63 2° fuoco



64 2° fuoco

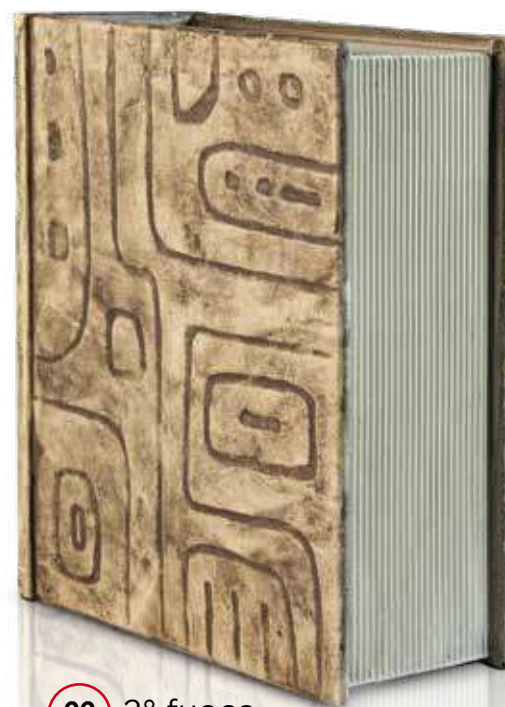

66 2° fuoco



119/1 2° fuoco



110 1° fuoco

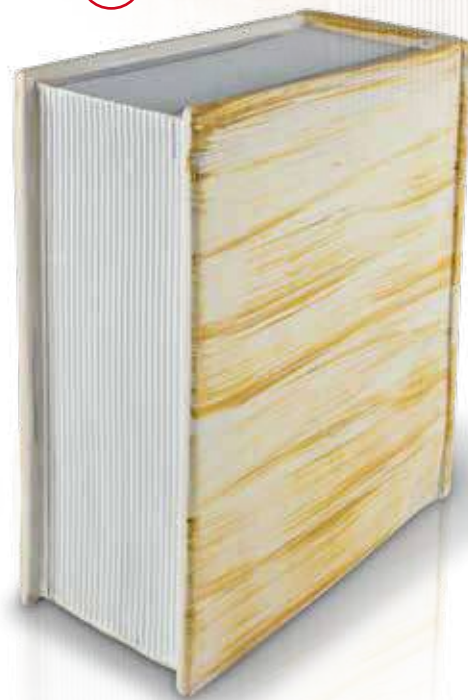

111 1° fuoco



112 1° fuoco



130/1 3° fuoco



16 3° fuoco



19 3° fuoco



20 3° fuoco



26 3° fuoco

UR 4 - Ø18 X H51 - Lt 5



21 3° fuoco



22 3° fuoco



23 3° fuoco

UR 5 - Ø22 X H40 - Lt 5



30 3° fuoco

UR 6 - Ø30 X H37 - Lt 5



103 3° fuoco

UR 6 LAMPADA GRANDE - H60 X Ø45 (cappello) - Lt 5



103/M 3° fuoco

UR 6 LAMPADA MEDIA - H55 X Ø35 (cappello) - Lt 3



103/P 3° fuoco

UR 6 LAMPADA PICCOLA - H44 X Ø25 (cappello) - Lt 1



104 3° fuoco



130/3 3° fuoco



22/L 3° fuoco

UR4 LAMPADA - H75 - Ø45 (cappello) - Lt 5



35/N 3° fuoco

UR 10 - H30 x Ø20 - Lt 5



92/4N 3° fuoco

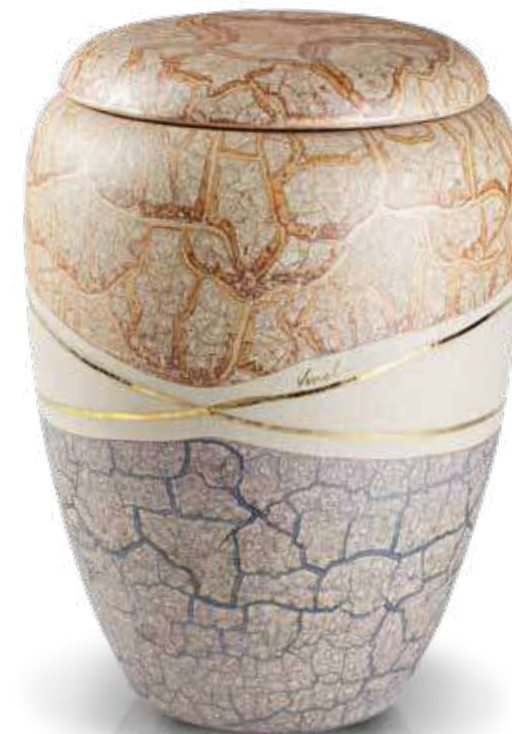

54/1 3° fuoco

UR 10/B PORTABOSSOLO - H35 x Ø25 - Lt 8



111/N 1° fuoco



110/N 1° fuoco



112/N 1° fuoco



12 3° fuoco

UR 2 - H30 X Ø20 - Lt 5



11 3° fuoco



10 3° fuoco

UR 1 - H30 X Ø20 - Lt 5



6 3° fuoco



54/2 3° fuoco



A6/N 1° fuoco



A8/N 1° fuoco



A9/N 1° fuoco

UR AB5 - H30 X Ø20 - Lt 5

MINIURNE



92/6

UR-APIRO3

H11 X L11X P11 - It 0,3

UR-A-PIR15

H18 X L17X P17 - It 1,5

UR-A-PIR05

H12 X L12X P12 - It 0,5



73/2 3° fuoco



95/1 3° fuoco



92/7 3° fuoco



51/1 3° fuoco

UR-A-CUBE7

H7,5 x L7,5 X P7,5 - It 0,2

UR-A-CUBE05

H8,5 x L8,5 X P8,5 - It 0,5

UR-A-CUBE15

H13 x L13 X P13 - It 1,5



100/1 3° fuoco



92/5 3° fuoco



73/1 3° fuoco



74/1 3° fuoco

UR-CUORE P

H9,5 X L11 X P10 - It 0,3

UR-CUORE05

H10 X L12 X P12,2 - It 0,5

UR-CUORE15

H12 X L13 X P12 - It 1,5



210/1 3° fuoco



72/1 3° fuoco



73/3 3° fuoco



73/4 3° fuoco



73/5 3° fuoco



73/6 3° fuoco

UR-EGG02

H11x Ø9 - lt 0,2

UR-EGG05

H16x Ø11 - lt 0,5

UR-EGG12

H20x Ø14 - lt 1,2

UR-EGG3

H26x Ø18 - lt 3



210/2 3° fuoco



211 3° fuoco



74/2D 3° fuoco



A35 3° fuoco

UR-ASTE05

H6x6x13,5 - lt 0,5 -

UR-ASTE15

H12x20x20 - lt 1,5 -

UR-ASFE02

cm Ø 4,5 - lt 0,2

UR-A-SFE05

Ø 11- lt 0,5

UR-A-SFE15

Ø 15- lt 1,5



212 3° fuoco



F92 3° fuoco



F98 3° fuoco



F71 3° fuoco



F73 3° fuoco



F56 3° fuoco

UR A FOTO05 - H7 x L20 X P16 - Lt 0,8

UR A FOTO - H8 x L20 X P16 - Lt 1,5

PORTAFOTO



301 3° fuoco



302 3° fuoco



303 3° fuoco



304 3° fuoco



305 3° fuoco



306 3° fuoco



307 3° fuoco

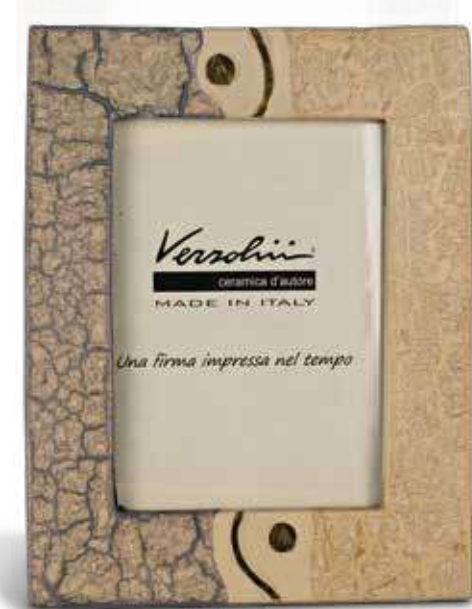

308 3° fuoco